

AD-S200

棒形闪光灯头
Stick Light Flash Head

使用手册
Instruction Manual

前言

感谢您购买神牛产品!

AD-S200 是一款可以配合 AD200/AD200Pro 使用的棒形闪光灯头。紧凑轻便, 拥有 200Ws 强劲功率; 具备最简便的安装方式, 一推即可; 常用于人像拍摄、摄影棚拍摄、珠宝拍摄、医疗拍摄、户外拍摄等拍摄场景。

警告

- ▲ 请勿私自拆卸产品, 如产品出现故障须由本公司或授权的维修人员进行检查维修。
- ▲ 请勿让儿童接触本产品。
- ▲ 禁止拆卸、撞击、挤压或投入火中, 若出现严重鼓胀, 请勿继续使用。
- ▲ 请勿放置在超过 50°C 的高温环境中。
- ▲ 请勿将闪光灯头正对人眼闪光 (特别是婴儿的眼睛), 否则可能会在短时间内造成视力障碍。
- ▲ 请勿在化学品、可燃性气体或其他特殊物质附近使用闪光灯, 这些物质在特殊情况下可能对闪光灯发出的瞬间强光敏感, 有可能导致火灾或电磁干扰。
- ▲ 在这些场合下, 请注意相关警告标识。
- ▲ 请保持干燥, 本产品不能防水, 在雨天及潮湿环境下请注意防水。
- ▲ 若发生任何故障, 请立即关闭闪光灯电源。

部件

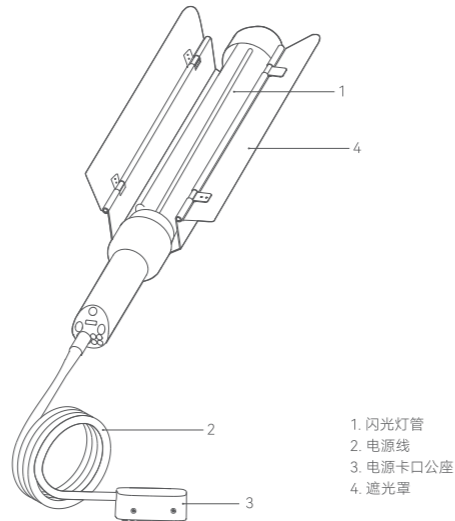

1. 闪光灯管
2. 电源线
3. 电源卡口座
4. 遮光罩

物料清单

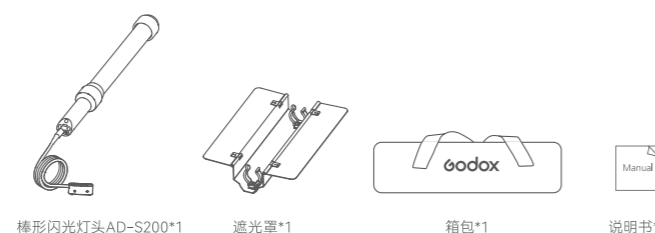

使用说明

1. 连接口袋灯AD200/AD200Pro

将 AD-S200 的电源卡口座对准 AD200/AD200Pro 灯头卡口座卡槽插入, 最后往前推动完成安装。

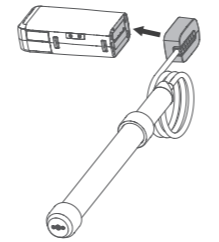

2. 拆卸AD-S200

按下 AD200/AD200Pro 灯头解锁按钮的同时, 将 AD-S200 电源卡口座往后推动完成拆卸。

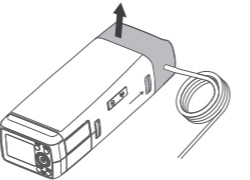

3. 拆卸遮光罩

在断电的情况下, 左手托住遮光罩背部的上部分, 右手大拇指抵住夹环边缘, 稍微用力往右掰的同时将闪光灯管往上提取出来。

注: 切记请勿用蛮力。

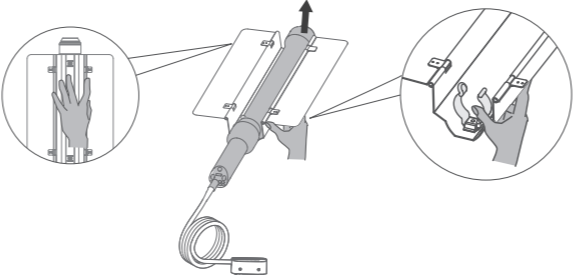

规格参数

型号	AD-S200
闪光灯功率	200Ws
闪光灯色温	5800K±200K
尺寸 (不含电源线, 含遮光罩)	652mm*210mm*60mm
净重 (含遮光罩)≈	1.12kg

规格和参数如有变更, 恕不另行通知。

维护保养

闪光灯在工作时, 如发现异常, 应立即关掉电源, 查明原因。

灯体应避免震动, 平时注意表面除尘。

灯体稍有发热为正常现象, 无特别需要时, 勿连续引闪。

闪光灯所有维修概由本厂指定可供原厂配件的维修部负责。

1 年保修, 消耗品如灯管等物料, 不在 1 年保修范围。

经发现, 擅自检修此闪光灯, 将取消闪光灯 1 年保修期, 维修需要收取相关费用。

如果本品出现故障或者被水淋湿, 在专业人员维修后方可继续使用。

如有技术更改, 恕不另行通知。

Foreword

Thank you for purchasing!

Stick Light Flash Head AD-S200 has a compact structure, 200Ws strong power and convenient installing method. It can be collocated with AD200/AD200Pro with a simple push, quite suitable for portrait shooting, studio shooting, jewelry shooting, medical shooting, outdoor shooting, etc.

Warning

- ▲ Do not disassemble. Should repairs become necessary, this product must be sent to an authorized maintenance center.
- ▲ Keep out of reach of children.
- ▲ Stop using this product if it breaks open due to extrusion, falling or strong hit. Otherwise, electric shock may occur if you touch the electronic parts inside it.
- ▲ Do not leave or store the flash unit if the ambient temperature reads over 50°C.
- ▲ Do not fire the flash directly into the eyes (especially those of babies) within short distances. Otherwise, visual impairment may occur.
- ▲ Do not use the flash unit in the presence of flammable gases, chemicals and other similar materials. In certain circumstance, these materials may be sensitive to the strong light emitting from this flash unit and fire or electromagnetic interference may result.
- ▲ In certain circumstance, please pay attention to the relevant warnings.
- ▲ Always keep this product dry. Do not use in rain or in damp conditions.
- ▲ Turn off the devices immediately in the event of malfunction.

Name of Parts

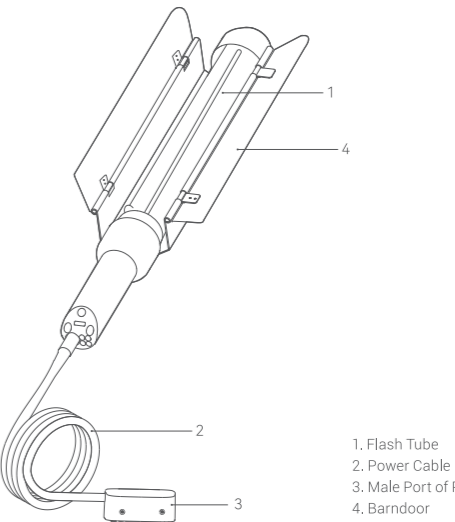

1. Flash Tube
2. Power Cable
3. Male Port of Power Socket
4. Barndoor

What's Inside

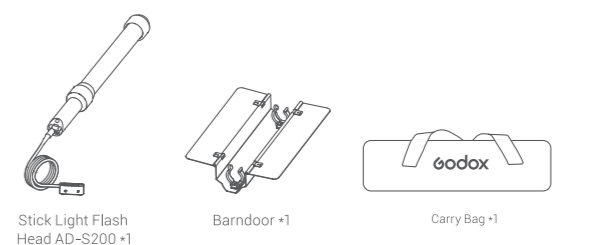

Instructions for Use

1. Connecting to Pocket Flash AD200/AD200Pro

Insert the male port of power socket of AD-S200 into the female port of AD200/AD200Pro flash head, push forward to connect.

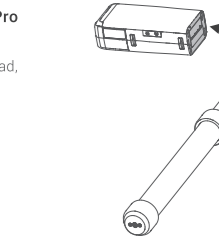

2. Detaching AD-S200

Press the locking button of AD200/AD200Pro and pull out the male port of power socket of AD-S200.

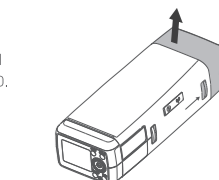

3. Detaching Barndoor

Turn off the flash, hold the upper back of the barndoor with your left hand, press your right thumb against the edge of the clamp ring and break it slightly to the right while pulling the flash tube upwards.

Note: Please do not use brute force.

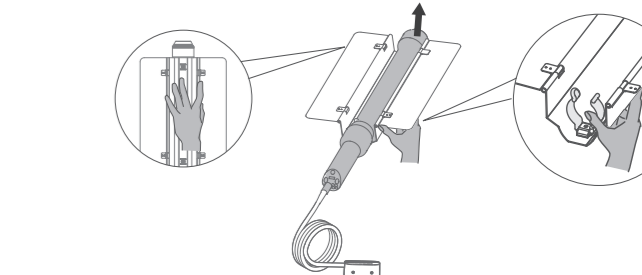

Technical Data

Model	AD-S200
Flash Power	200Ws
Flash CCT	5800K±200K
Dimension (excluding the power cable and including the barndoor)	652mm*210mm*60mm
Net Weight(including the barndoor)≈	1.12kg

Changes made to the specifications or designs may not be reflected in this manual.

Maintenance

Shut down the device immediately should abnormal operation be detected.

Avoid sudden impacts and the product should be dedusted regularly.

It is normal for the light beads to be warm when in use.

Avoid continuous flashes if unnecessary.

Maintenance of the light must be performed by our authorized maintenance department which can provide original accessories.

This product, except consumables, is supported with a one-year warranty.

Unauthorized service will void the warranty.

If the product had failures or was wetted, do not use it until it is repaired by professionals.

Changes made to the specifications or designs may not be reflected in this manual.

FCC Statement

This device complies with part 15 of the FCC Rules. Operation is subject to the following two conditions: (1) This device may not cause harmful interference, and (2) this device must accept any interference received, including interference that may cause undesired operation.

Any Changes or modifications not expressly approved by the party responsible for compliance could void the user's authority to operate the equipment.

Note: This equipment has been tested and found to comply with the limits for a Class B digital device, pursuant to part 15 of the FCC Rules. These limits are designed to provide reasonable protection against harmful interference in a residential installation. This equipment generates uses and can radiate radio frequency energy and, if not installed and used in accordance with the instructions, may cause harmful interference to radio communications. However, there is no guarantee that interference will not occur in a particular installation. If this equipment does cause harmful interference to radio or television reception, which can be determined by turning the equipment off and on, the user is encouraged to try to correct the interference by one or more of the following measures:

- Reorient or relocate the receiving antenna.

- Increase the separation between the equipment and receiver.

- Connect the equipment into an outlet on a circuit different from that to which the receiver is connected.

- Consult the dealer or an experienced radio/TV technician for help.

Declaration of Conformity:

GODOX Photo Equipment Co.,Ltd. hereby declares that the This equipment are in compliance with the essential requirements and other relevant provisions of EU Directive 2014/35/EU、2014/30/EU. They are allowed to be used in all EU member states. For more information of DoC, Please click this web

<https://www.godox.com/eu-declaration-of-conformity/>

产品保修

尊敬的用户, 本保修卡是申请保修服务的重要凭证, 请您配合销售商填写并妥善保管, 谢谢!

产品信息	型号	产品条码
用户信息	姓名	联系电话
	通信地址	
销售商信息	名称	
	联系电话	
	通信地址	
	销售日期	
备注		

注: 此表应由销售商盖章确认。

产品信息

本文件适用于相关《产品保修信息》(见后面说明)所列产品, 其他非属此范围的产品或部件(如促销品、赠品及其他出厂后附加的部件等)不在此保修承诺内。

保修期

产品及部件的相应保修期按相关的《产品保修信息》执行。保修期自产品首次购买日起算, 购买日以购买产品时保修卡登记日期为准。

如何获得保修服务

您可直接与产品销售商或授权服务机构联系, 也可拨打神牛产品售后服务电话, 与我们联系, 由我们的服务人员为您安排服务。申请保修时, 您应提供有效的保修卡作为保修凭证, 方可获得保修。如您不能提供有效的保修卡, 则在我们确认产品或部件属于保修范围的情况下, 也可以为您提供保修, 但这不作为我们的义务。

不适用保修的情况

如产品存在下列情况, 本文件项下的保证和服务将不适用: ①产品或部件超过相应保修期; ②错误或不适当使用、维护或保管导致的故障或损坏, 如: 不当搬运; 非按产品合理预期用途使用; 不当插拔外接设备; 跌落或外力挤压; 接触或暴露于不当温度、溶剂、酸碱、水浸或潮湿环境; ③由非神牛授权机构或人员安装、修理、更改、添加或拆卸造成的故障或损坏; ④产品或部件原有识别信息被修改变更或删除; ⑤无有效保修卡; ⑥使用非法授权、非标准或非公开发行的软件造成的故障或损坏; ⑦因不可抗力或意外事件造成的故障或损坏; ⑧其他非因产品本身质量问题导致的故障或损坏。遇上述情况, 您应向相关责任方寻求解决, 神牛对此不承担任何责任。因非在保修期或保修范围内的部件、附件或软件导致产品不能正常使用的, 不是保修范围内的故障。产品使用过程中正常的脱色, 磨损和消耗, 不是保修范围内的故障。

产品保修和服务支持信息

产品的保修期和服务类型按以下《产品保修信息》执行:

产品类别	选件名称	保修期(月)	保修服务类型
部件	电路板	12	客户送修
	电池	3	客户送修
	充电器等带电性能的部件。	12	客户送修
其他	如闪光灯管、造型灯泡、外壳、保护罩、锁紧装置、包装等。	无	无保修

神牛产品售后服务电话 0755-29609320-8062

Warranty

Dear customers, as this warranty card is an important certificate to apply for our maintenance service, please fill in the following form in coordination with the seller and safe-keep it. Thank you!

Product Information	Model	Product Code Number
Customer Information	Name	Contact Number
	Address	
Seller Information	Name	
	Contact Number	
	Address	
	Date of Sale	
Note		

Note: This form shall be sealed by the seller.

Applicable Products

The document applies to the products listed on the Product Maintenance Information (see below for further information). Other products or accessories (e.g. promotional items, giveaways and additional accessories attached, etc.) are not included in this warranty scope.

Warranty Period

The warranty period of products and accessories is implemented according to the relevant Product Maintenance Information. The warranty period is calculated from the day (purchase date) when the product is bought for the first time, and the purchase date is considered as the date registered on the warranty card when buying the product.

How to Get the Maintenance Service

If maintenance service is needed, you can directly contact the product distributor or authorized service institutions. You can also contact the Godox after-sale service call and we will offer you service. When applying for maintenance service, you should provide valid warranty card. If you cannot provide valid warranty card, we may offer you maintenance service once confirmed that the product or accessory is involved in the maintenance scope, but that shall not be considered as our obligation.

Inapplicable Cases

The guarantee and service offered by this document are not applicable in the following cases: ① The product or accessory has expired its warranty period; ② Breakage or damage caused by inappropriate usage, maintenance or preservation, such as improper packing, improper usage, improper plugging in/out external equipment, falling off or squeezing by external force, contacting or exposing to the improper temperature, solvent, acid, base, flooding and damp environments, etc; ③ Breakage or damage caused by non-authorized institution or staff in the process of installation, maintenance, alternation, addition and detachment; ④ The original identifying information of product or accessory is modified, alternated, or removed; ⑤ No valid warranty card; ⑥ Breakage or damage caused by using illegally authorized, nonstandard or non-public released software; ⑦ Breakage or damage caused by force majeure or accident; ⑧ Breakage or damage that could not be attributed to the product itself. Once met these situations above, you should seek solutions from the related responsible parties and Godox assumes no responsibility. The damage caused by parts, accessories and software that beyond the warranty period or scope is not included in our maintenance scope. The normal discoloration, abrasion and consumption are not the breakage within the maintenance scope.

Maintenance and Service Support Information

The warranty period and service types of products are implemented according to the following Product Maintenance Information:

Product Type	Name	Maintenance Period(month)	Warranty Service Type
Parts	Circuit board	12	Customer sends the product to designated site
	Battery	3	Customer sends the product to designated site
	Electrical parts e.g. battery charger, etc.	12	Customer sends the product to designated site
Other Items	Flash tube, modeling lamp, shell, lamp cover, locking device, package, etc.	No	Without warranty

Godox After-sale Service Call +86-755-29609320(8062)



深圳市神牛摄影器材有限公司
地址: 深圳市宝安区福海街道塘尾社区耀川工业区厂房2栋 电话: 0755-29609320(8062)
传真: 0755-25723423 邮箱: godox@godox.com

GODOX Photo Equipment Co., Ltd.
Add.: Building 2, Yaochuan Industrial Zone, Tangwei Community, Fuhai Street, Bao'an District, Shenzhen 518103, China Tel: +86-755-29609320(8062) Fax: +86-755-25723423
E-mail: godox@godox.com

godox.com
Made in China | 705-ADS200-00

